

INSTRUCTION MANUAL

IH RICE COOKER

MODEL : RZ-GHE18 (1.8L TYPE)

HOUSEHOLD

Content

Before usage

- Important safeguards 2
- Parts, accessories, control panel,
display screen 4
- How to set current time 5

Before cooking rice

- Preparation (Tips to cook tasty rice) 6
- How to cook rice 8
(White rice, Jasmine rice, Japanese rice,
Brown rice, Rice Berry, Mixed rice, Sticky rice)
- How to set Timer 10
(Set the time to finish)
- How to warm rice 11
(Tips for keeping rice warm and tasty)

Cooking Food

- How to slow cook manually 12
- How to bake a cake manually 13
- How to steam manually (sticky rice
and others) 14

Clean and care

- Cleaning 15
(Steam cap/rice scoop/rice scoop holder/measuring
cup/inner pot cap/inlet vent/outlet vent/inner pot/
sealing ring/inner lid/temperature sensor)
- How to get rid of an unpleasant odor 16

Problems and solutions

- How to cope with the following problems 17~ 19
(problems related to cooking/reheating/Timer/
sound/LCD display/blackout while in use etc.)

คู่มือสอนทำอาหาร

- Mixed Rice with Shrimp Past 20
- Braised Chicken with Onion 20
- Steamed Snow Fish 21
- Congee and 5 Vegetables 21
- Butter Cake 22
- Cerealbuns 22
- Stewed Beef 23
- Healty Rice Porridge 23

Specification

Specification

24



MODEL : RZ-GHE18

Let's Cook Tasty Rice

2.3 mm Thick Iron Pot

HITACHI IH Rice Cooker

Thank you for selecting Hitachi Rice Cooker **IH**. Please read this instruction manual carefully before using the product and keep it for future reference. The explanation herein are referred to RZ-GHE18 model.

Please Read "Important Safeguards" for your understanding and correct application

→ page 2-3



Important safeguards

This product is for household use only. Do not use for industrial purpose.



Following indications in this manual will minimize the risk of injury to users/other people and damage to properties. Please understand them in full before reading the main content.

■ Lists of cautions

The danger and damages that could occur upon misuse of the products are classified by the following symbols and messages.









 Warning This symbol denotes a hazard that “can result in death or severe serious injury”.	 Caution Indicate hazard that possibility causes “human damage or property damage” only when a user ignores it and mishandles the product.
------------------------------------------------------------------------------------------------------------------------------------------------------------------------------------	------------------------------------------------------------------------------------------------------------------------------------------------------------------------------------------------------------------------------------

Mark examples

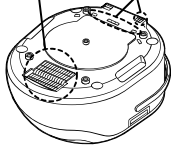

 This mark indicates “warnings or cautions”	 This mark indicates “prohibition”	 This mark indicates “advice” things to follow
------------------------------------------------------------------------------------------------------------------------------	---------------------------------------------------------------------------------------------------------------------	-----------------------------------------------------------------------------------------------------------------------------------

Warning

To prevent shock, flame and fire

 <ul style="list-style-type: none"> ● Use this product with a AC plug rated 220V 15 A or higher. ● Make sure the plug fits fully to the socket. ● Wipe off dust on the blade or blade-installed face of the plug, if any. 	 
 <p>Never modify the product.</p> <ul style="list-style-type: none"> ● Never disassemble nor repair the product by any person except for service technical personnel. 	 <ul style="list-style-type: none"> ● Do not wet this product nor splash water onto this product ● Do not place the product near water
 <p>Do not use the product with wet hand.</p> <ul style="list-style-type: none"> ● Do not plug in and unplug with wet hand. 	<ul style="list-style-type: none"> ● The appliance must not be immersed or putting water in any part of the body. It may cause electric shock or short-circuit hazards.
 <ul style="list-style-type: none"> ● Do not operate the product with a damaged cord or plug or when electrical outlet is loose. ● Do not damage, modify, forcedly bend, pull, twist, bundle, bring near hot place/parts, pinch the cord or place heavy object on the cord. ● Do not insert metal object such as pin and wire or other foreign matter into a vent or gap. ● This appliance is not intended for use by persons(including children) with reduced physical , sensory or mental capabilities, or lack of experience and knowledge,unless they have been given supervision or instruction concerning use of the appliance by a person responsible for their safety. ● Children should be supervised to ensure that they do not play with the appliance. 	<p style="text-align: center;">Inlet vent Outlet vent</p> 
 <ul style="list-style-type: none"> ● The appliance normally cleaned after use. ● Stop using the product immediately if any abnormality found or the product show error. <ul style="list-style-type: none"> • The electric cord or plug is overheat. • When the cord is bended, the electric current is intermittent. • The temperature is unusually hot or smell of burning. • Feel electric current when touching the cooker. • The electric current is not cut off automatically. • The motor stops working, rotates slowly or unusually rotates. • Abnormal noise generated while the product is in use. • Water leakage. • Unusual noise or other unusual behavior. 	

To prevent burn hazards

 <p>To prevent burn hazards.</p> <ul style="list-style-type: none"> ● Do not put hand or face near the steam vent. ● Hot steam may be released during cooking process, keep the cooker away from children. ● While cooking, do not open the cap, shake or move the cooker. 	 <p style="text-align: center;">Steam vent</p>
 <p>When cooking in progress, food or liquid may overflow from the top lid and can open accidentally, causing skin burn.</p> <ul style="list-style-type: none"> ● Tightly close the lid by pressing center point until hear the “click”. ● Do not cook rice or food other than provided in the manual and cooking handbook. 	

! Attention

Do not use the cooker in following places

- Do not use the product near water or fire. (It may cause electric shock or electric leakage or fire).
- Do not place the cooker on unstable surface or flammable surface (It may cause fire.)
- Do not place the product on a location that cover the inlet vent, outlet vent or on the aluminum foil (It may cause overheating or skin hazards).
- If the product is placed near the wall, furniture or shelf in the kitchen, make sure that the steam released will not be trapped (dew from the steam may cause decolorize to the wall or furniture or deforming).
- Do not place the product on the location that the cap is not completely opened (touching the heating plate or dropping dew may cause skin hazards).

How to use the pug



Remove the plug



- Unplug from the socket when not in use (it may cause fire, skin hazards, electric shock, electric leakage or injury due to degraded insulation).
- Hold the plug while removing the cord (pulling the cord can cause skin injury).

To prevent burn hazards

- Check the correct cooking method before cooking rice "Porridge" mode requires more water than other cooking mode and the process may release hot water which user should be careful.
- Carry out cleaning of this product after the product has been cooled down (touching any hot part could result in burn).
- Wait until the inner lid cools down before removing
- Completely open the lid and scoop the rice (Hot dew may splash on skin).



Do not touch

- Do not touch hot parts such as inner pot, inner pot handle, inner lid, steam vent while using or right after cooking.
- Do not touch the inner pot when carrying or moving the rice cooker. Close the lid and grab the pot handle. (It may cause injury or burn hazards.)
- Do not touch the lock button when carrying or moving the rice cooker. (Failure to follow this caution may cause opening of the outer lid.)
- Lower down the pot handle when cooking (hot steam may overheat the handle).

To prevent accidents



- Do not use any inner pot other than the one provided exclusively for this product. (Failure to follow this caution could result in malfunction, overheat or fire.)
- Do not use the product if there is small metal object or aluminum foil remained in the pot (it may cause overheat or fire).

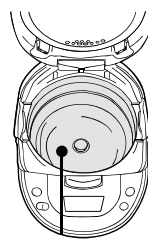

Inner pot



- If you are using pacemaker, consult your physician before using this cooker (the product function may affect the pacemaker).



- Place the product away from magnetic sensitive items (data stored in magnetic stripe of credit card or similar may be damaged).

Before usage

Note

- Do not use the product when the pot is empty (it may overheat).
- Do not use this product with foreign matter on the inner pot as shown in the picture. Always keep the pot clean. (Failure to follow this caution may cause failure and/or improper cooking.)

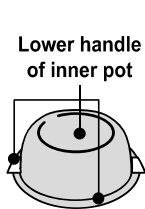

Lower handle of inner pot

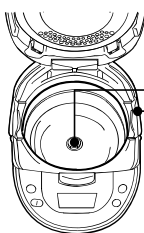

Temperature sensor
Place where inner pot handle should be located

- Do not put the inner pot on the direct fire nor heat it up in the microwave oven or place on electro-magnetic stove. (It may cause deformation of the inner pot and/or peeling off of fluorocarbon-resin coating.)
- Do not place a damp cloth on the cooker. (It may cause discoloration, deformation or malfunction.)



- Do not use the rice cooker near TV, radio, telephone or wireless phone. (Cause interference or distorted screen).
- If the pot falls down and gets broken, please stop using it and bring to the dealer shop for checking and repairing.

Parts, Accessories, Control panel, Display screen

■ Main body

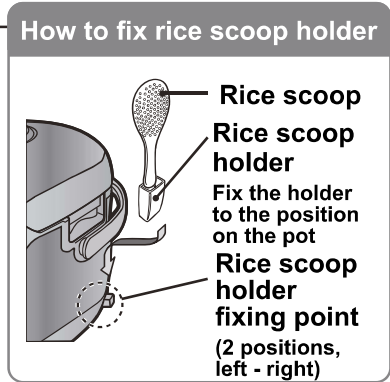
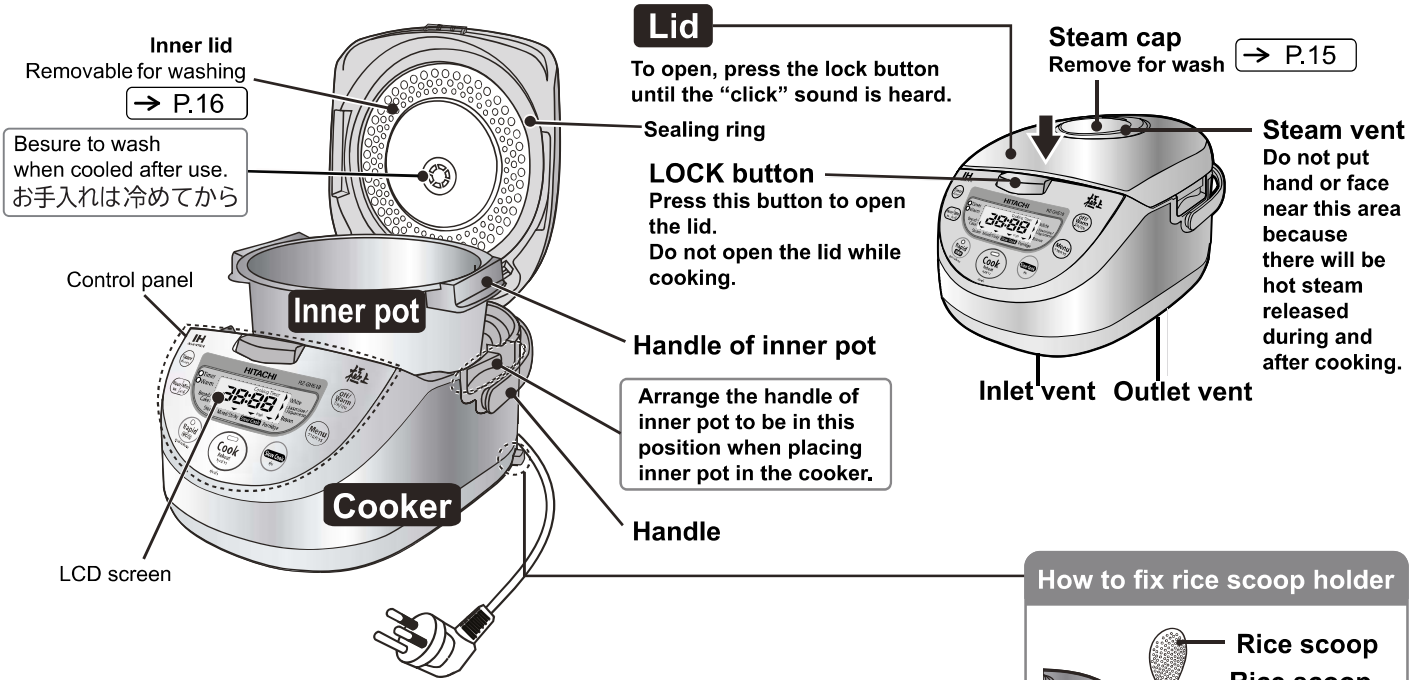

■ Accessories

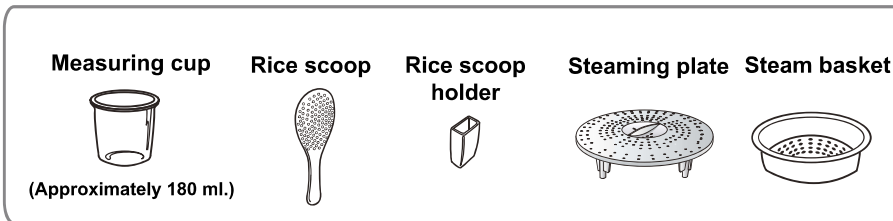

■ Control panel

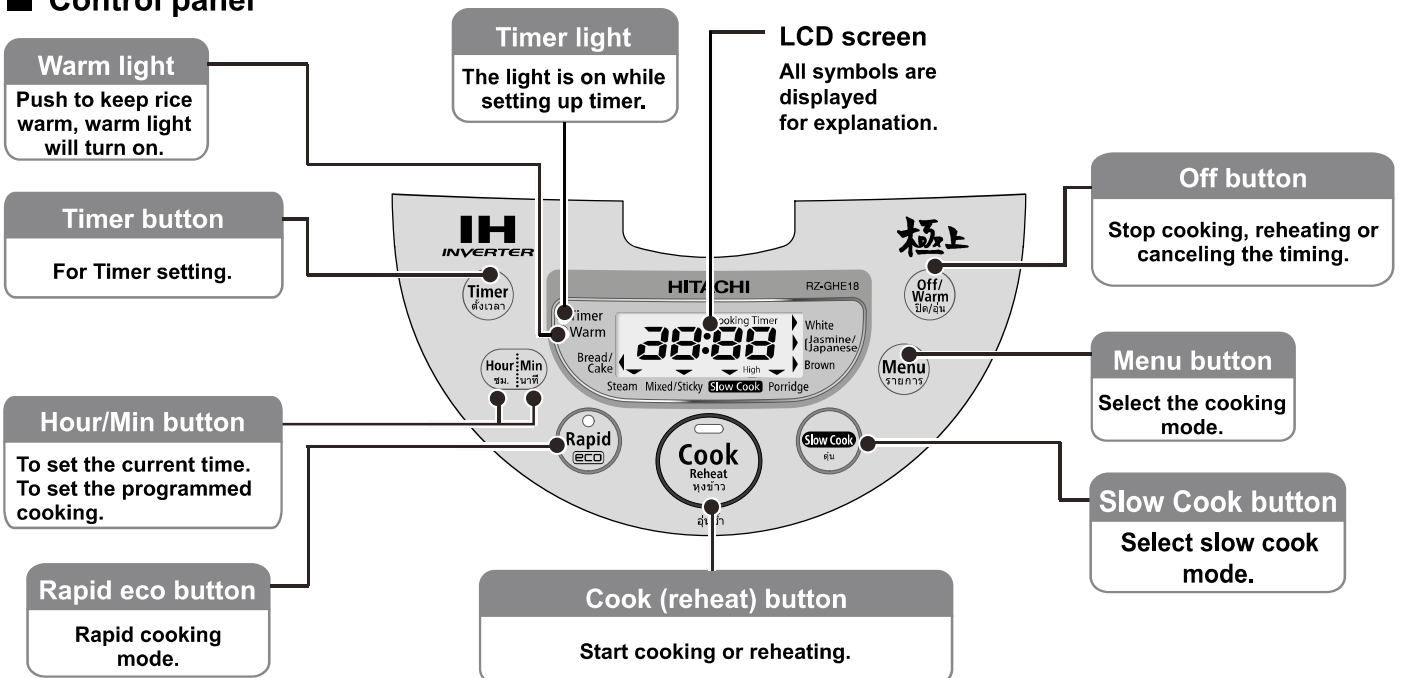

Symbol on "Cook (Reheat)" button here is embossed symbol 「○」 and off 「○」 for visually impaired.

Before usage

How to set current time

- The clock is powered by internal battery even the plug is pulled off.
- The clock may show about 2 minutes different during the first month of use due to the various room temperature. Please adjust the time as following:

Example: To adjust the time from "19:27" to be "20:30" (type of rice and cooking mode is only set for example).

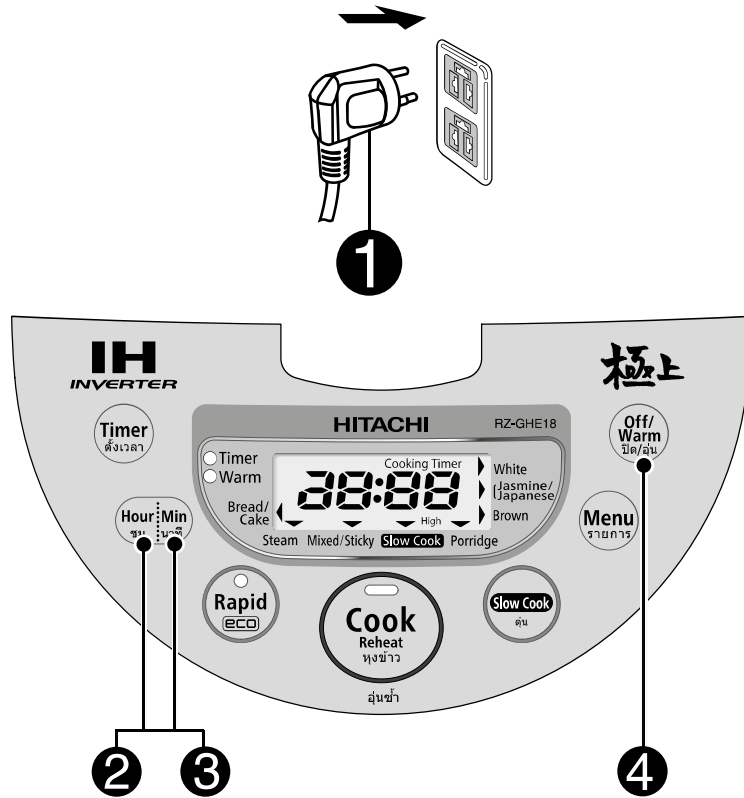

<p>1 Insert the plug to socket.</p>		<ul style="list-style-type: none"> ● Type of rice and cooking method set including current time (Off).
<p>2 Press Hour or Min and hold for a second to let the screen display blinking time.</p>		<ul style="list-style-type: none"> ● Timer cannot be set while cooking, warming, new timing and reheating.
<p>3 Press Hour or Min to set the time to "20:30".</p> <ul style="list-style-type: none"> ● the time will change each time you pressing the button. <ul style="list-style-type: none"> • Hour Increase by 1 hour • Min Increase by 1 minute • Press and hold to rapid the pace. 		<ul style="list-style-type: none"> ● The clock shows 24 hours. Midnight is 0:00, mid day is 12:00.
<p>4 Press Off/Warm to light on the screen.</p>		<ul style="list-style-type: none"> ● If Off button is not pressed after 60 seconds, the Timer will be canceled automatically.

Preparation for cooking (Tips to cook tasty rice)

1 Measuring rice

Measure rice correctly

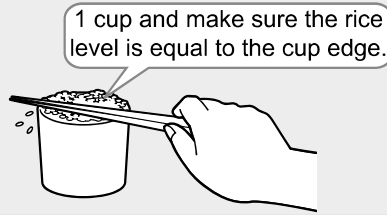

Measure rice with the given measuring cup.
Cup measures approximately 180 ml.

Note: Do not use the measuring cup from other source.
(This may cause difference in rice amount measured.)

2 Clean rice

Stir rice in clean water and quickly pour out the initial rinsing water.

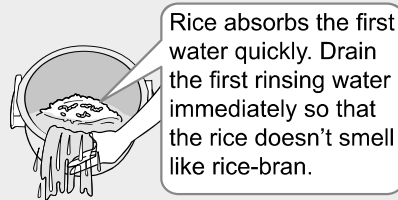

Repeat the procedure until the water becomes clear.

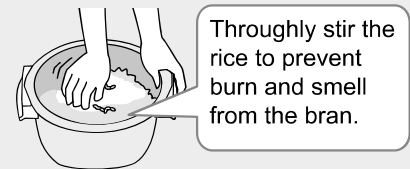

Note: Do not use metal whisk or other metal tools when stirring rice in the inner pot (it may cause peeling off fluorocarbon-resin coating.)

3 Adjust the water level

Flatten out the surface of rice. Put the pot on a smooth surface. Adjust the water level to suit the type, quantity of rice and method of cooking.

Example, to cook 4 cup of "White Rice"

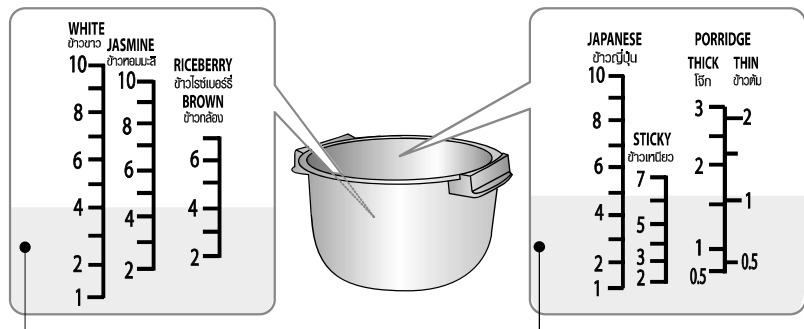

Water levels are calculated roughly. You can adjust the amount of water as you desire.

Note:

- Do not use hot water. (It may cause wet rice)
- It may cook rice too wet or turn into yellow colour when using too alkaline water. Cooking rice with hard water (such as mineral water) may cause rice to be crispy, dry or hard, adjust the water as appropriate.
- Reduce the water level scale for newly harvested rice to prevent the rice to be wet. Newly harvested rice contain a lot of water.
- Adjust the water level as shown in the handbook (mostly on the rice package).

4 Add rice to the pot

Wipe off the water and foreign matter around and on the bottom of the inner pot.

Wipe off the water and foreign matter around the inner pot.

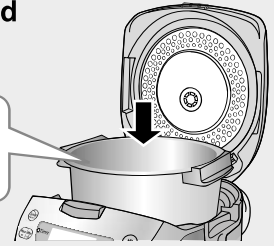

- Note:**
- Do not put the inner pot in the cooker when there is water or foreign matter around (to avoid malfunction or uneven rice cooking).
 - Place the inner pot holder to be consistent to the position of the cooker.

5 Check the lid

How to reattach the inner lid

Warning:



- before cooking rice, remove the inner lid and make sure that there is no left over rice or food. Do not forget to reattach the inner lid after checking.

6 Close the lid and reattach the steam cap.

Slowly close the lid until the “click” noise is heard and then reattach the steam cap

Press the lock button until the “click” noise is heard. (The lid cannot be closed if the inner lid is not attached)

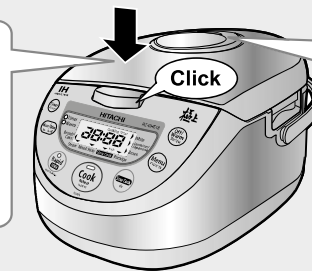

Reattach the steam cap



Warning:



- Slowly close the lid until the “click” noise is heard (otherwise the cap will open automatically and may cause the skin burn).
- Make sure that the steam cap is even (otherwise it may release hot water or steam).

7 Insert plug to the socket

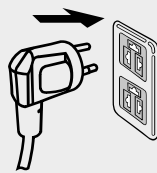

LCD will display type of rice and method of cooking set and current time.



- Note:** Noise while working or the sparks when plugging might cause by inverter charging, which is not considered as malfunction.

Start cooking rice after preparation

● How to cook rice

(White rice, Jasmine rice, Japanese rice, Brown rice, Mixed rice, Sticky rice, Rice Berry)

→ P.8,9

● How to use the Timer

(Set the time to finish)

→ P.10

How to cook rice (White rice, Jasmine rice, Japanese rice, Brown rice, Rice berry, Mixed rice, Sticky rice)

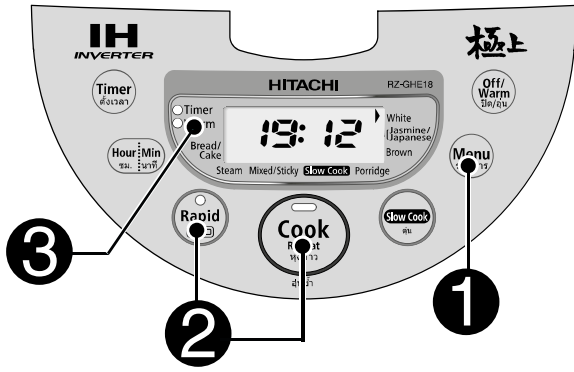

Attention: Check the cooking method. Selecting other mode "porridge" requires lots of water and may cause hazard from the hot water released.

Example of using "White"

1 Press **Menu** to move **▶** to the selected "Rice".

- Press to slide **▶**

● Rapid light will blink only for White, Jasmine, Japanese.

2 There are 2 types of cooking rice.

2.1 Normal cooking

- Press the Cook button **[Cook]**

2.2 Rapid Cooking

- Press "Rapid" Button **[Rapid]**

2.3 You will hear the melody (warning sound) and it will start cooking.

- "Cook" or "Rapid" light will be on

▼

After 3 seconds

▼

Showing time for cooking

● The cooking mode can be selected to suit each type of rice.

● When cooking "Brown" "Porridge" "Mix/Sticky", the clock will show current time and change into remaining time a few minutes before the cooking is completed.

3 The melody (warning sound) rings, the cooking is finished.

- The "Warm" light will light on.

Stir the rice after cooking.

The hour is shown as 0h

Before cooking rice

Knowledge for rice

Cooking mode	Type of rice and recommended method	Amount of rice (cup)	Water level Indicator	Cooking time (min)
Normal Cooking	WHITE	1-10	WHITE	40-70
	JASMINE	2-10	JASMINE	50-70
	JAPANESE	1-10	JAPANESE	55-70
	BROWN	2-7	BROWN	80-100
	PORRIDGE/THICK	0.5-3	PORRIDGE/THICK	60-80
	PORRIDGE/THIN	0.5-2	PORRIDGE/THIN	60-80
	MIXED (WHITE)	2-7	WHITE	60-100
	RICEBERRY	2-7	BROWN	85-100
	MIXED (BROWN)	2-7	BROWN	60-80
	STICKY	2-7	STICKY	50-60
Rapid Cooking	WHITE	1-10	WHITE	28-50
	JASMINE	2-10	JASMINE	28-50
	JAPANESE	1-10	JAPANESE	28-50

● "Rapid" takes short time for cooking, therefore, the rice may be a little bit wet and hard.

● Seasoning for mixed rice should be placed on the top of the rice, without stirring.

● The amount of steam released is varied, depending on the cooking mode.

*Power supply 220V AC, Room temperature 25°C, Water temperature 28°C

*Cooking time depends on voltage, room temperature, water temperature and water level including type of rice.

● Cooking time is based on previous setting of time, temperature etc.

● The time of cooking may be increased or suspended while cooking in progress to adjust rice to be tast_y.

● There may be dew drops when open the lid right after cooking. This is not considered as malfunction.

● After the cooking is finished, the middle of the rice might be compressed or the rice along the inner pot may be softer. This is because the heat generated from electromagnetic waves inside the pot to ensure that the rice will be thoroughly cooked.

● If the rice is not stirred properly, it may absorb steam and become too glutinous or hard.

How to set Timer

(Set the time to finish)

- Pre-set time to finish cooking.
- If the set-time is close to the current time, the cooking will start immediately.

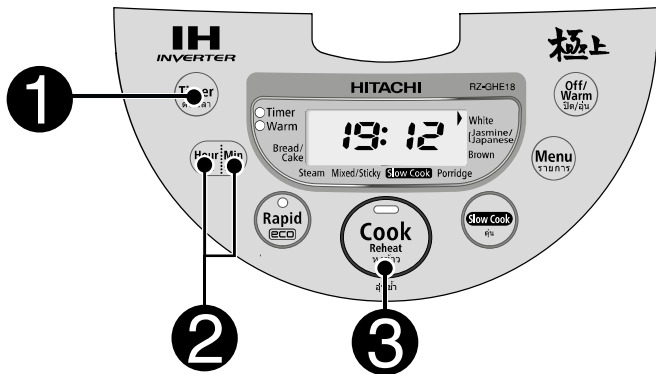

Note:

- Please do not use Pre-set time for mixed rice (it may change property of the ingredient or they may not be properly cooked).
- You can set the Pre-set time within the maximum 12 hour.

Example: Set "Timer" to "7:30"

In case of selecting "White"

Check the current time, set the time if it's not correct. → P.5

Before cooking rice

1 Press "Timer" after selecting "Cooking Mode".

Press .

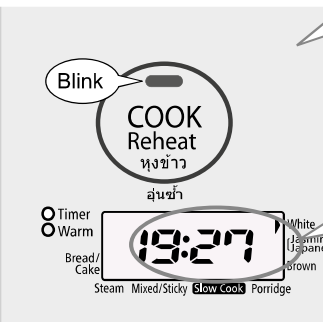

● Knowledge about rice and cooking method
→ P.8,9

● The default factory time setting or previous time set will appear.

2 Press or to set the time to "7:30".

- The time will change each time you press the button.

- Increase by 1 hour
- Increase by 1 minute
- Press and hold to rapid the pace.

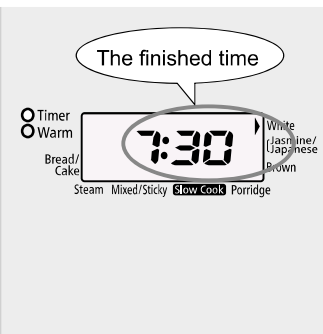

The finished time

3 Press the "peep peep" sound will alarm. The setting is completed.

.

- "Cook (Reheat)" light will be off and "Timer" light will be on.

When the melody (warning sound) is on, the cooking is finished and the cooker will change to warming mode automatically.

- "Warm" light turn on.



● The time set will be recorded

● Press "OFF Warm" button to cancel the programmed setting.

Light on

Light on

Show finished time

● How to warm the rice
→ P.11

How to warm rice

(Tips for keeping rice warm and tasty)

- After cooking is finished, the cooker will automatically change it to "Warm". If the warming, generates smell or makes the rice sticky, "Warming" advice is as follows :

Type of rice	Cooking mode	Warming	
WHITE	WHITE	<ul style="list-style-type: none"> ● After the cooking is finished, the cooking mode will change to Warm automatically (WARM light is on). 	<ul style="list-style-type: none"> ● The Warm Mode which use normal temperature can run 24 hours and the Warm mode which use high temperature can run 12 hours. ● Do not Warm. (Warming may affect quality, smell or consistency of the rice).
JASMINE JAPANESE	JASMINE JAPANESE		
BROWN RICE BERRY	BROWN		
STICKY	STICKY		
MIXED	MIXED RICE		
WHITE BROWN	PORRIDGE		
		<ul style="list-style-type: none"> ● To stop Warming, press [off] (Warm light will be off). 	

- Warming may accumulate moisture inside the lid, inner lid or inner pot. This prevents the rice from getting dried, it is not classified as the cooker malfunction.

Tip for Warming tasty rice

- Stir rice occasionally while Warming.
- If the rice quantity is low, accumulate the rice in the middle of the pot (to prevent the rice from getting dried or get clumped).
- Use as less time for warming as possible. Do not warm rice more than 24 hours (in case of warming with high temperature, time should not exceed 12 hours). (it may cause decolorizing and smell). [→ P.16](#)
- Do not warm other rice than white rice (Brown, Porridge, Mixed / Sticky, Riceberry).
- Stir rice well before warming. Do not leave rice scoop in the pot while warming and do not reheat the cold rice.
- You can keep the rice tasty by wrapping it with plastic wrapping paper and warm it in microwave oven.



Before cooking rice

How to heat the rice in Warm mode

- You can warm the rice again if the rice becoming cool.
- It is recommended that the rice level should be lower than level 3 of water level of [WHITE RICE].

1 Stir rice occasionally during warming and keep the surface flat.

Note: ● Do not warm the rice many times (it may cause the rice to get dried or even burned).

2 Press  while warming.

- [COOK (REHEAT)] light blinks
- New warming mode will start automatically in around 10 minutes.

● When the rice is still hot after cooking or when the rice has been cooled down, the warning sound will peep and you cannot warm the rice again).

3 After the cooking is finished, cooker will change to warm automatically. Warm light will be on.



- To stop warming, press OFF (Warm light will be off)

How to slow cook manually

● Time to slow cook, please refer to the Auto Recipe Cook Book.

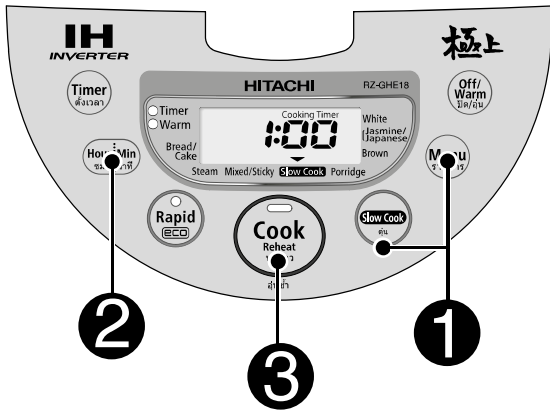

Warning

- Do not use for other purpose than cooking as specified in the Cook Book.
- Do not open the lid while cooking, if it is necessary, press Off button to stop procedure and open the lid. (Be careful - risk of burn skin)

Example, "Slow Cook" 3 hours, 30 minutes

How to slow cook manually
Cooking

1 Press **Slow Cook** select "Slow Cook"

or Press **Menu** to move to "Slow Cook"

- The menu will change each time the button is pressed

● You can select the menu directly by press "Slow Cook"

● Each time you press Menu, the indicator will move to another menu position.

● There are 2 types of Slow Cook:
- Slow Cook "High" temperature
- Slow Cook "Low" temperature

● Each time you press Hour, the time will increase by 30 minutes or press Min the time will be decreased by 30 minutes and open the lid. (Be careful risk of burn skin)

● For Slow Cook duration, please see reference in attached Cook Book for adjustment of proper time.

2 Press **Hour** or **Min** .

3 hours, 30 minutes

- The time will change each time you press the button.

- **Hour**: Increase by 30 minutes
- **Min**: Decrease by 30 minutes

3 Press **Cook** the melody (warning sound) will ring. Start heating.

- "Cook (Reheat)" light is on
- The melody (warning sound) rings, the cooking is finished. Put the food to other container.

Note: ● Do not warm or keep the cooked food in the pot (fluorine coating on the inner pot may be damaged).

● The time set will be recorded.

● To cancel the Slow Cook time, Press "OFF" button.

The hour is shown as 0h

How to bake a cake manually

● Duration of baking a cake, please see reference in attached Cook Book.

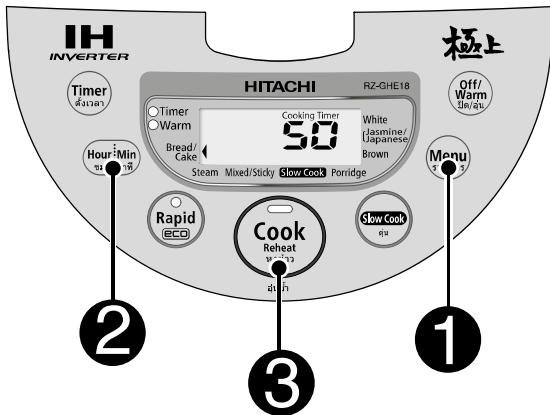

Warning

- Do not use for other purpose than cooking as specified in the Cook Book.
- Do not open the lid while cooking, if it is necessary, press Off button to stop procedure and open the lid. (Be careful risk of burn skin)

Example, "Bread / Cake" 60 minutes

1 Press **Menu** to move to "Bread/Cake".

- The menu will change each time the button is pressed.

● Each time you press Menu, the indicator will move to another menu position.

2 Press **Hour** or **Min** to set time for baking cake 50 minutes.

- The time will change each time you press the button.

- **Hour**: Increase by 5 minutes
- **Min**: Decrease by 5 minutes

● Each time you press Hour, the time will increase 5 minutes or press Min the time will decrease by 5 minutes.

● For Baking a cake, please see reference in attached Cook Book for setting of proper time.

3 Press **Cook** the melody (warning sound) will ring. Start heating.

- "Cook (Reheat)" light is on
- The melody (warning sound) rings, the cooking is finished. The cooker will change to warm automatically.
- Press Off/Warm to cancel the operation of cooker and close the lid immediately.

Note: ● Do not warm or keep the cooked food in the pot (fluorine coating on the inner pot may be damaged).

● The time set will be recorded.

● Press "OFF" button to cancel the baking.

● The hour is shown as h

● Show current time

How to bake a cake manually

Cooking

How to steam manually (sticky rice and others)

● Duration for steam, please see reference in attached Cook Book.

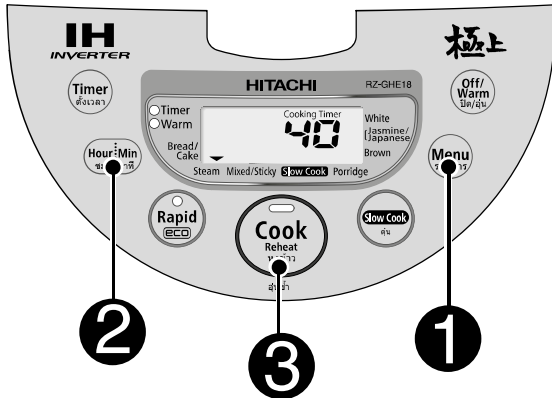

Warning

- Do not use for other purpose than cooking as specified in the Cook Book.
- Do not open the lid while cooking, if it is necessary, press [Off] button to stop procedure and open the lid. (Be careful risk of burn skin).

Example, "Steam" 50 minutes

1 Press Menu to move to "Steam".

- The menu will change each time the button is pressed.

● Each time you press Menu, the indicator ▼ will move to another menu position

2 Press Hour or Min to set time for steaming 50 minutes.

- The time will change each time you press the button.

- Hour: Increase by 1 minutes
- Min: Decrease by 1 minutes

● Each time you press Hour, the time will increase 1 minute or press Min the time will decrease by 1 minute.

● For Steam duration, please see reference in attached Cook Book for adjustment of proper time.

3 Press Cook the melody (warning sound) will ring. Start heating.

- "Cook (Reheat)" light is on
- The melody (warning sound) rings, the cooking is finished. The cooker will change to warm automatically.
- Press Off / Warm to cancel the operation of cooker and close the lid immediately.

Note: ● Do not warm or keep the cooked food in the pot (fluorine coating on the inner pot may be damaged).

● The time set will be recorded.

● Press "OFF" button to cancel the steaming.

● Show current time.

Cleaning:

Attention



Make sure that you unplug cooker and cooker is cold enough for maintenance (otherwise it may cause risk of burn skin)

Note:

- Avoid using benzene, thinner, polishing or alkaline scrub powder to clean the cooker. (It may damage the surface.)
- Use dishwasher detergent (neutral) for cleaning (other detergent may damage the surface).
- Wash with sponge or soft fabric. Do not use plastic brush or other brush (using brush may damage the surface).
- Do not wash the cooker in dish washing machine and dryer (it may damage, deform or decolorize the cooker).

Steam cap (Wash every time after use)

Remove steam cap and wash with dishwasher detergent (neutral) and sponge or soft fabric.

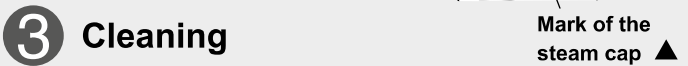
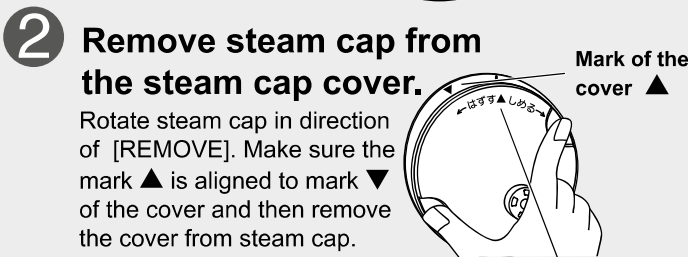
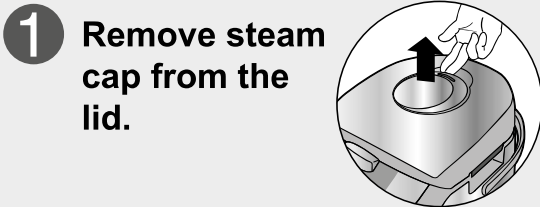

Align the ▲ mark of steam cap to ▼ mark of steam cap cover. Make sure that the 3 nails are well fixed, then rotate the cover to しめる direction to ▼ mark of the cover.

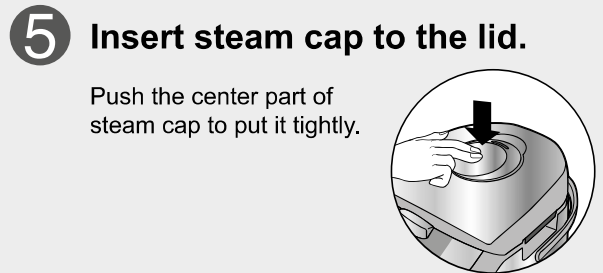

The cooker and lid (clean when dirty)

- Wipe with damp cloth.
- Do not rinse with water or put into the water.

**Rice scoop (Wash every time after using)
Rice scoop holder / Measuring cup (wash when dirty)**

- Wash with dishwasher detergent (neutral) and sponge or soft fabric

Inlet vent / outlet vent (clean once a month)

Do not use vacuum machine to clean the dust from inlet and outlet vents.

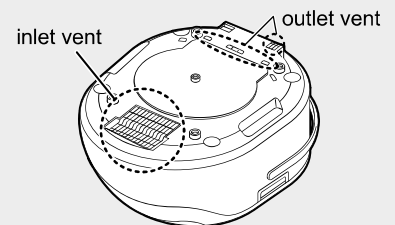

Inner pot (wash every time after use)

Remove inner pot from cooker and wash with sponge or soft fabric with dishwasher detergent (neutral).

- It may not cook properly if the inner pot is deformed. To avoid that, handle it with care.
- While using inner pot, partial discoloring may occur which will not affect rice cooking or your health.
- To avoid damaging fluorine coating, please do as follows:
 - Use provided rice scoop
 - Do not wash spoons and other containers in the inner pot
 - Do not clean the inner pot by brush or scrubbing powder
 - Do not use metal scoop to stir or take food from the pot
 - Do not use vinegar with the inner pot
- Fluorine coating will be worn by repetitive use, handle it with care.
- Fluorine coating is harmless to human.

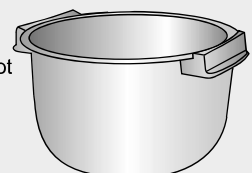

Sealer ring (wash every time after use)

Wash together with inner lid.

- Sealer ring cannot be removed, do not try to pull it off.

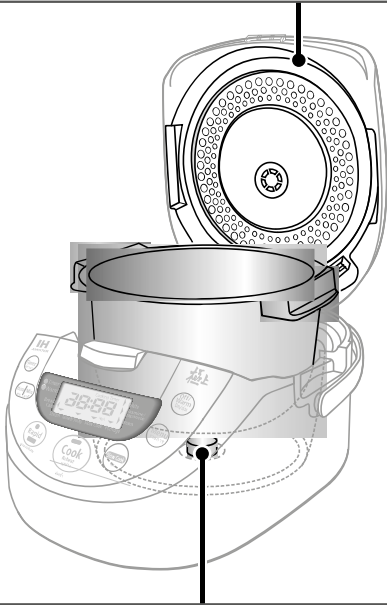

Temperature sensor (check before cooking)

If there is burnt food stick the pot, remove it with damp cloth and/or waterproof sand paper (no.#600). After removing the food, clean the surface with damp cloth.

- Do not rinse with water.

Inner lid (wash every time after use)

Remove from the lid and wash with soft material such as sponge by using dishwasher detergent, then wipe.

1 Remove inner lid from the outer lid.

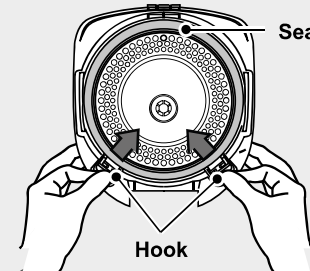

- Push levers (both sides) toward the arrows to remove.
- Sealer ring cannot be removed.

2 Wash and rinse to clean off blockage and dirt in the inner lid.

3 Attach inner lid to the outer lid.

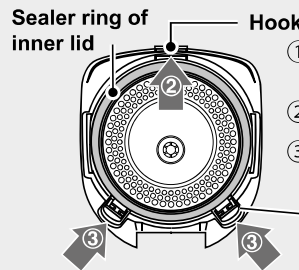





- 1 Insert inner lid and turn the sealer ring on top.
- 2 Insert hook into a groove of the lid.
- 3 Push levers (both sides) until clicking sound is heard.

Note: To prevent cooking without inserting inner lid, the lid cannot be closed if the inner lid is not inserted properly.

How to get rid of an unpleasant odor

If there is odor after cooking mixed rice, cooking food or warming, clean the pot by following methods.

1	Pour water to the inner pot	Water level Pour until water level reach 4 of [White]
		Use water only, do not use washing detergents etc.
2	Press  to align with [White]	
3	Press 	

4	After 60 minutes, press 	[Rapid/Eco] light is on The melody (warning sound) rings. The cooker will start heating.
		[Rapid/Eco] light is off The melody (warning sound) rings. The cooker will start heating.
		● The cooker will not stop automatically, do not forget to press [Off] button.
5	After the cooker cool down, pour out the water and wipe off the moisture inside inner pot.	● Right after the water is boiled, the inner pot and inner lid is still hot, please wait until the cooker cools down. Then pour out the water and wipe off the remaining moisture inside. ● Some odor cannot be totally removed.

Problems and solutions:

Please check the following points before contacting the service personnel.

Problems

Check list

Cooking rice

- too soft
- too sticky
- hard
- The rice grain is hard inside
- not properly cooked
- not evenly cooked

- Amount of rice and adjustment of water level → P.6
 - Measure the rice using the provided cup. Make sure not to use more than the [amount specified] of each menu.
 - If the rice is too soft, reduce the water level. If the rice is too hard, add more water.
- Rinsing rice → P.6
 - Rinse rice until the water become clear.
 - Rice that does not need to be cleaned: anyway rinse it off if the water is not clear. Stir well to mix rice and water.
- The water for rinsing and cooking rice → P.6
 - Rinse rice with cool water. Do not use warm or hot water (Using warm water may make the rice sticky and wet).
 - The rice may be too sticky and become yellow when using too alkaline water. The rice may be crispy or hard when cooking with hard water (mineral water). Adjust the proper amount of water to suit each rice.
- How to cook rice → P.10
 - In case of programmed cooking, reduce the water level since the rice will absorb more moisture (to prevent rice to be too soft).
- Stirring rice.
 - Stir the rice as soon as it is cooked. (This will evaporate extra water - this will prevent the rice from getting to sticky).
- Bottom of inner pot and temperature sensor getting dirty → P.15,16
 - Remove foreign substances.
- Cooker stop working while cooking rice.
 - In case the cooker stops working while cooking is in progress due to "OFF" or "Warm" is pressed, plug is removed or blackout the rice will not be cooked thoroughly.
- Power supply.
 - Using extension leads or plug in the socket with other appliances may cause power failure and the rice may not be thoroughly cooked. Do not use extension leads and plug cooker to the individual socket.

- Burnt rice

- Cooking white rice at high temperature may cause the rice to be brown. Other type of rice may be burnt or turn brown which is not considered as unusual.
- Rinsing rice → P.6
 - White rice: Rinse rice until the water is clear.
 - Rice that does not need to be cleaned: anyway rinse it off if the water is not clear. Stir it well to mix rice and water.
 - Bottom of inner pot and temperature sensor getting dirty → P.15,16

- Overflowing boiled water

- Amount of rice and adjustment of water level → P.6
 - Measure the rice using the provided cup.
- Rinsing rice → P.6
 - White rice: Rinse rice until the water is clear.
 - Un-waxed rice: rinse off if the water is not clear. Stir it well to mix rice and water.
- Blockage of dirty parts → P.15
 - How to remove blockage and foreign substance from steam cap.
- How to assemble the parts → P.15,16
 - Do not forget to attach steam cap and inner lid before cooking.
- How to check cooking mode.
 - Cooking in [Porridge] mode requires lot of water. Hot water may overflow while cooking. Please be careful.

- The middle of the rice is swelling
- Thin film

IH heating and conducting heat for inner pot may cause the middle part of the rice swelling or the part connect to the inner pot look whiter - which is not considered as unusual. This firm is caused by starch from rice grain which enhance the taste of the rice. Therefore, cooking rice at high temperature will enhance better taste and is not considered as unusual aspect.

- Mixed rice is not well cooked

- Adding seasoning and other ingredient.
 - Add seasoning to the water. Adjust water level and then stir to prevent the seasoning settle down to the bottom of the pot.
 - Add other ingredient to the rice after the water level is adjusted. Then mix the ingredient to the rice after the rice is cooked. (If seasoning or other ingredient is settled on the bottom of the pot, it may affect heat induction).
- Amount of seasoning and other ingredients.
 - The proper amount of other ingredient is between 30-50% of amount of the rice. Minimize the amount of other ingredient if such ingredient is very oily.
 - Reduce amount of soy sauce.
- How to cook rice → P.10
 - Cook immediately without programmed setting, (programmed setting may affect taste of ingredient or settle the ingredient).

Problems and solutions

Problems and solutions:

→ continued

Please check the following points before contacting for the service personnel.

Problems

Check list when

Cooking rice

- Long duration of cooking

Immersing rice and steaming rice will be proceed automatically comparing to cooker without micro-computer system, and uses longer time - which is not considered as unusual aspect.

- Quantity of rice and adjustment of water level → P.6

→ Measure the rice using the provided cup. Make sure not to use more than the [amount specified] of each menu.

- Rinsing rice → P.6

→ Rice that does not need to be cleaned: anyway rinse it off if the water is not clear. Stir well to mix rice and water.

- Cooker stop working while cooking rice.

→ If the power supply fails while cooking, the duration will be extended accordingly to the time suspended.

- Unusual odor of the rice and inner pot

There might be plastic or rubber smell during the first usage which will fade after sometime. The other odor may occur after cooking mixed rice or using pot for other food - which is not considered as unusual aspect.

- Cleaning rice → P.6

→ White rice: Clean rice until the water is clear.

→ Rice that does not need to be cleaned: anyway rinse it off if the water is not clear. Stir well to mix rice and water.

- How to stir rice → P.11

→ Stir the rice as soon as it is cooked. (This will evaporate excessive water which prevent the rice from getting sticky).

- How to cook rice → P.10

→ Do not wait before cooking the rice for too long time during summer.

- Cooker stop working while cooking rice.

→ In case the cooker stop working due to the "OFF" is pushed, plug is removed, it may cause odor.

- Dirty parts → P.15,16

→ Remove dirt from inner lid, steam cap.

- Excessive amount of accumulated moisture

- Opening cap right after the rice is cooked may show dew drops which is not considered as unusual aspect → P.9

- Unpleasant odor
- Become yellowish

Warming rice for a long duration or repeatedly reheating may cause smell and turn rice to yellow - which is not considered as unusual aspect.

- Warming rice → P.11

→ Do not put rice scoop on the rice while warming. Do not warm the cold rice.

- Rinsing rice → P.6

→ White rice: Clean rice until the water is clear.

→ Rice that does not need to be cleaned: anyway rinse it off if the water is not clear. Stir well to mix rice and water.

- How to stir rice → P.11

→ Stir the rice as soon as it is cooked. (This will evaporate excessive water which prevent the rice from getting sticky).

- Dirty parts → P.15,16

→ Remove dirt from inner lid, steam cap.

- Dried rice

Warming rice for a long time or repeatedly reheating may dry rice - which is not considered as unusual aspect.

- Quantity of warming rice → P.11

→ If the amount of rice to be warmed is little, accumulate the rice in the center of the pot before warming.

- Dirty parts → P.15,16

→ Remove dirt from sealer ring, temperature sensor, edge and bottom of the inner pot.

- Part assembly → P.15,16

→ Do not forget to attach steam cap, inner lid before cooking.

- Dew drops
- Sticky rice

Warming may cause dew drops accumulation inside of lid, inner lid or inner pot. This prevents the rice from getting dried, it is not the cooker's malfunction.

- How to stir rice → P.11

→ Stir the rice as soon as it is cooked. (This will evaporate extra water which prevent the rice from getting sticky and smelly).

- Quantity of warming rice → P.11

→ If the amount of rice to be warmed is little, accumulate the rice in the center of the pot before warming.

Warm

Problems and solutions:

Please check the following points before contacting for the service personnel.

Problems		Check list when															
Warm	<ul style="list-style-type: none"> ● Unable to warm the rice. 	<p>The alarm will ring and the rice cannot be warmed when it is still hot right after cooking and when its get cooled down after warming. → P.11</p>															
	<ul style="list-style-type: none"> ● How to cook rice. ● The rice is not cooked within the set time. 	<p>The programmed cooking is set to cook rice within specific time. The cooking will start close to the set time. The procedure takes time to complete, and sometimes, it may not finish within set time. Make sure you check current time and adjust it accordingly (the system clock contains 24 hours). → P.10</p>															
Noises	<ul style="list-style-type: none"> ● Noise while working. 	<p>The following alarm / noises will occur while cooking, warming:</p> <table border="1"> <thead> <tr> <th>When plugging in</th> <th colspan="4">While in use (cooking, warming etc.)</th> </tr> </thead> <tbody> <tr> <td> <ul style="list-style-type: none"> ● Operating noise <p>(may cause sparks) Charging noise of inverter circuit</p> </td> <td> <ul style="list-style-type: none"> ● Frizzling noise <p>Releasing steam</p> </td> <td> <ul style="list-style-type: none"> ● Wind noise <p>Cooler blower</p> </td> <td> <ul style="list-style-type: none"> ● Operating noise </td> <td> <ul style="list-style-type: none"> ● Whistling noise </td> </tr> <tr> <td colspan="5"> <p>IH Heating system of inner pot</p> </td> </tr> </tbody> </table>	When plugging in	While in use (cooking, warming etc.)				<ul style="list-style-type: none"> ● Operating noise <p>(may cause sparks) Charging noise of inverter circuit</p>	<ul style="list-style-type: none"> ● Frizzling noise <p>Releasing steam</p>	<ul style="list-style-type: none"> ● Wind noise <p>Cooler blower</p>	<ul style="list-style-type: none"> ● Operating noise 	<ul style="list-style-type: none"> ● Whistling noise 	<p>IH Heating system of inner pot</p>				
	When plugging in	While in use (cooking, warming etc.)															
<ul style="list-style-type: none"> ● Operating noise <p>(may cause sparks) Charging noise of inverter circuit</p>	<ul style="list-style-type: none"> ● Frizzling noise <p>Releasing steam</p>	<ul style="list-style-type: none"> ● Wind noise <p>Cooler blower</p>	<ul style="list-style-type: none"> ● Operating noise 	<ul style="list-style-type: none"> ● Whistling noise 													
<p>IH Heating system of inner pot</p>																	
LCD screen	<ul style="list-style-type: none"> ● Change immediately. 	<p>The cooking procedures will be adjusted automatically to enhance the rice taste. Hence, the time of cooking may be varied, it is not considered as malfunction.</p>															
	<ul style="list-style-type: none"> ● Not show. 	<p>The time of cooking will not be displayed when selecting other cooking modes than [White][Jasmine][Japanese]. The monitor will display current time instead</p>															
	<ul style="list-style-type: none"> ● Monitor displays [H0] or [-:--]. 	<p>When monitor displays H0, press Off button and it will turn to -:-- , set time to current time.</p>															
	<ul style="list-style-type: none"> ● The LCD screen will be off when the cooker is unplugged. 	<p>In case of -:-- or H0 displaying every time when plugging in or out, it means that lithium battery inside the pot gets flat. However, you can still cook and warm rice, but cannot set current time and set programmed cooking. You need to replace lithium battery (require payment) from the dealer shop where you purchase the cooker. (Lithium battery is special kind of battery which you cannot change it yourself.)</p>															
	<ul style="list-style-type: none"> ● LCD screen displays [C1] or [C2]. 	<p>Will appear and the cooker will be off when the power failure due to connecting cord or the plug share socket with other appliances. Do not use extension leads and do not share socket with other electric appliances when cooking.</p>															
	<ul style="list-style-type: none"> ● LCD screen displays [H1] – [H8]. 	<p>The LCD screen does not show current time even after pushing [Off] button or the LCD screen displays same content, please bring the cooker for repair at the dealer shop where you purchase the cooker.</p>															
	<ul style="list-style-type: none"> ● Uneven color. 	<p>After sometime of usage, the fluorine coating color will fade, which will not affect the rice cooking or your health. → P.15</p>															
Noises	<ul style="list-style-type: none"> ● Scratches. 	<p>To avoid damaging fluorine coating, please follow these instructions: [Do not use metal scoop to stir or take food from the pot] [Do not wash cutlery or plates in the inner pot] [Do not use vinegar with inner pot] [Do not wash with scrubbing powder or brush] [Use the provided rice scoop only] → P.15</p>															
	<ul style="list-style-type: none"> ● Power failure while in use. 	<table border="1"> <thead> <tr> <th>During cooking</th> <th>While warming</th> </tr> </thead> <tbody> <tr> <td> <p>After the power come back, the cooker continue cooking, but in case the power failure takes more than 30 minutes, the cooker will cancel the cooking</p> </td> <td> <p>After the power come back, the cooker continue warming, and cooker will cancel the warming, depending on rice temperature</p> </td> </tr> </tbody> </table>	During cooking	While warming	<p>After the power come back, the cooker continue cooking, but in case the power failure takes more than 30 minutes, the cooker will cancel the cooking</p>	<p>After the power come back, the cooker continue warming, and cooker will cancel the warming, depending on rice temperature</p>											
During cooking	While warming																
<p>After the power come back, the cooker continue cooking, but in case the power failure takes more than 30 minutes, the cooker will cancel the cooking</p>	<p>After the power come back, the cooker continue warming, and cooker will cancel the warming, depending on rice temperature</p>																
<ul style="list-style-type: none"> ● Steam leaks from the place between the lid and cooker. 	<p>Sealer ring or heating plate is deformed, please replace with new inner lid.</p>																
<ul style="list-style-type: none"> ● Noise interference into television and radio. 	<p>The cooker may cause noise and wave interference with the TV, therefore, please place the cooker away (approximately 3 meter distance).</p>																

- After checking all the points above and you still experience problems, please contact the store Where you purchased the product.
- If inner pot is deformed or its fluorine coating is damaged, please purchase new one.

Cooking book

Mixed Rice with Shrimp Paste

(Serves 2-3) Ingredients:

- 1 cup jasmine rice
- 1 cup brown rice
- 3 tablespoons shrimp paste
- 1 tablespoon vegetable oil
- 10 Shrimps, deveined
- 1 tablespoon fish sauce
- 1/4 teaspoon salt
- 1 teaspoon sugar
- 3 tablespoons carrot, fine diced
- 1/2 cup shimeji mushroom, cut
- 3 tablespoons lemongrass, finely sliced
- 3 tablespoons fingerroot (Krachai), finely sliced
- 2 tablespoons Fresh green peppercorn
- 1/2 cup roasted, or fried cashew nuts
- 1 tablespoons kaffir leaves, finely sliced
- 1 cup raw mango, finely sliced
- A bunch coriander
- Bird's eye chilies, finely chopped
- Water

Instruction:

1. Combine two rice and rinse well. Place in a colander to drain.
2. Put shrimp paste and oil in the pot. Press "Cook" button and cook for 7-8 minutes. Add shrimps and stir until cooked. Remove shrimps from the pot and set aside.
3. Put rice in the pot and close the lid. When rice is hot, open the lid and stir for 5-8 minutes until rice turn transparent.
4. Add water to second mark of the pot (brown rice). Season to taste with fish sauce, salt, and sugar. Add carrots, mushroom, and stir. Close the lid. Press Menu and select "Mixed/Sticky". Press "Cook" button. When rice is cooked, "Off/Warm" button light is on. Open the lid and add lemongrass, fingerroot, peppercorn, kaffir leaves, cashew nuts, and cooked shrimps. Stir to combine. Transfer to serving plate and decorate with coriander served with sliced mango and chopped chilies.



Braised Chicken with Onion

(Serves 4-5) Ingredients:

- 500 grams chicken wings
- 5 cups plain water
- 150 orinji mushrooms
- 6 small onions, halved
- 150 grams tomatoes
- 1 1/2 tablespoons light soy sauce
- 1 tablespoon oyster sauce
- 2 teaspoons seasoning sauce
- 1/4 teaspoon salt
- 1/4 - 1/2 teaspoon ground pepper
- 2-3 Chinese celery leaves

Instruction:

1. Marinate the chicken wings with 1 tablespoon light soy sauce, oyster sauce and ground pepper for 10 minutes.
2. Put plain water into the inner pot. Close the lid. Press "Rapid eco". Open the lid when the water start to boil or after 10-15 minutes
3. Add chicken wings and the rest of the seasonings and stir. Close the lid. Press "Slow Cook". Select "High". Set the timer for 1 hour. Press "Cook". Open the lid and add onions, tomatoes and orinji mushrooms. Close the lid to warm about 30 minutes and press "Off".
Serve the chicken soup with Chinese celery leaves on top. Serve hot.



Cooking book

Steamed Snow Fish

(Serves 2) **Ingredients:**

- 2 snow fish fillets 100 grams each
- 1 tablespoon light soy sauce
- 1 teaspoon sesame oil
- 2 teaspoons cooking oil
- 3 tablespoons ginger, finely sliced
- 1/4 cup shimeji mushroom
- 1 spring onion, finely chopped
- 1/2 red chili, finely sliced lengthwise
- Plain water

Instruction:

1. Put water into the inner pot. Place the Steam tray in the pot.
2. Place the fish on a plate. Season with light soy sauce, sesame oil, cooking oil, sprinkle with sliced ginger and shimeji mushroom. Place the fish plate in the Steam tray. Close the lid. Press "Menu". Select "Steam" Set the timer for 20 minutes. Press "Cook". Lift the fish plate from the steam basket. Sprinkle with chopped spring onion and red chili. Serve hot.



Congee and 5 Vegetables

(Serves 2-3) **Ingredients:**

- 1 cup jasmine rice
- 3-3 1/2 cups vegetables stock
- 400 grams minced chicken
- 1 egg white
- 2 tablespoons coriander roots, grounded
- 2 tablespoons garlic, finely chopped
- 2 teaspoons ground pepper
- 1 teaspoon salt
- 1/4 cup light soy sauce for pork marinating
- 2 1/2 tablespoons light soy sauce for the congee
- 1/2 cup each of carrots, pumpkins and white radish, diced
- 1/2 cup broccoli, cut into pieces
- 1 cup shimeji mushrooms
- 1/3 cup ginger, finely sliced
- 2 spring onions, chopped
- Water
- Poached eggs, cooked as preferred

Instruction:

1. Rinse the jasmine rice and drain in a colander.
2. Put the rice into the inner pot. Add water up to the level marked PORRIDGE. Spread the rice evenly.
3. Close the lid. Press Menu. Select "Porridge" and press "Cook". When the rice is cooked, the warm light will be on. Press "Off".
4. Open the lid and add the vegetable stock. Add carrots, pumpkins, white radishes, broccoli, shimeji mushrooms and close the lid. Press "Rapid eco". About 5-10 minutes.
5. Mix minced chicken with coriander root, garlic, light soy sauce and egg white. Beat the mixture to create stickiness. Spoon the chicken into small ball and put into the pot.
6. Season the congee with salt, light soy sauce and stir. Close the lid for 10 minutes or until the chicken is cooked.
7. Spoon the congee into the serving bowls and sprinkle with sliced ginger, chopped spring onion and top with poached egg. Serve hot.



Cooking book

Butter Cake

(Serves 5-6)

Ingredients

- Instant butter cake mix 300 grams
- Eggs 4
- Water 30 grams
- Salted butter 180 grams
- Whipped cream 500 grams
- Fruits (e.g. peach, kiwi, sweetened red cherry)
or garnish

Instruction:

1. Beat butter until it rises. Add eggs then mix. Add butter cake mix and water in alternate and continue to beat for 3 minutes. Pour the mixture into the inner pot. Press the "Menu" button select "Bread/Cake" menu set timer for 30-35 minutes and press "Cook". Once the cake is baked, the "Warm" light will show. Press the "Off" button.
2. Remove the inner pot. Flip the cake onto a grill and leave to cool down.
3. Slice the cake into 3 layers. Coat the whipped cream on each layer of the cake and then around the cake. Decorate with fruits like peach, kiwi and sweetened red cherry.



Cerealbuns

(Serves 5-6)

Bread Ingredients

- Bread flour 175 grams
- Cake flour 25 grams
- Yeast 1 teaspoon
- Dough enhancer 1/2 teaspoon
- Milk powder 3/4 teaspoon
- Caster sugar 2 teaspoons
- Salt 1/2 teaspoon
- Cold water 125 grams
- Salted butter 25 grams
- 1/4 cup unsweetened condensed milk mixed with 2 tablespoons water for spreading baked bread
- Butter or shortening for spreading baked bread

Cereals

- Sunflower seeds 2 1/2 tablespoons
- Baked pumpkin seeds 2 1/2 tablespoons
- Baked melon seeds 2 1/2 tablespoons
- Roasted black sesame seed 2 1/2 tablespoons
- Roasted white sesame seed 2 1/2 tablespoons

Instruction:

1. Sift the two flours, dough enhancer and milk powder in a bowl.
2. Add yeast in the flour mixture and stir to combine and put in food processor.
3. Mix sugar, salt, and water together, Stir to dissolve and pour into the food processor. Attach dough hook and knead until mixtures hold together. Add butter and continue kneading until smooth. Take out and shape into a ball. Leave to rest 15 minutes.
4. Roll the dough into 10 X 16 inches rectangle shape. Sprinkle the cereals all over the dough. Roll the dough into a log. Slice the log into 7-8 pieces about 1 inch thick.
5. Arrange 8 rolls in 1.8-liter pot and 7 rolls in 1.0-liter pot. Cover the pot with plastic wrap and leave to rise until doubled. Brush the rolls with condensed milk mixed with water.
6. Place the inner pot with raised rolls in the Rice Cooker, close the lid and Press "Menu" button to select "Bread/Cake" program. Set timer 50 minutes or until cooked and golden brown. Press "Cook" button.
7. Invert the buns from the pot and spread all over with butter. Leave to cool on a rack.

Remark :

- Rolls must rise at least double its volume before put into the Rice Cooker. Otherwise the bread get heavy and tough.



Stewed Beef

(Serves 4-5) Ingredients:

- 500 grams beef chuck with fat cut into 1 1/2 inch cube
- 1/3 cup onion, finely chopped
- 2 tablespoons salted butter
- 100 grams carrot, julienned into 1/2 to 1 inch
- 5 pearl onions
- 150 grams potato, cut into 1 inch cube
- 10 cherry tomatoes
- 3 tablespoons tomato paste
- 1 teaspoon Worcestershire sauce
- 6 tablespoons ketchup
- 1 1/2 teaspoons course salt
- 1/2 teaspoon ground pepper
- 3 – 4 bay leaves
- 1 1/2 cups stock or plain water
- 2 teaspoons all purpose flour



Instruction:

1. Put all ingredients in the inner pot. Stir to combine. Press “Slow Cook” set the timer for 90 minutes. Press Cook button. Cooking is completed when Off/Warm button light is green. Serve hot in a serving bowl.

Healthy Rice Porridge

(Serves 4-5) Ingredients:

- 1 cup jasmine rice
- 1 1/2 cups chicken, cut into pieces
- 8 cups plain water
- 1 cup boiled peanuts
- 1/2 cup cooked spinach, chopped
- 2 tablespoons mushroom sauce
- 1 cube chicken stock
- 1/2 teaspoon coarse salt
- 1 tablespoon light soy sauce
- 1/2 teaspoon ground pepper

Instruction:

1. Rinse the rice well and drain in a colander. Set aside.
2. Put all ingredients in the inner pot. Stir to combine. Close the lid. Press menu select “Porridge”. Press Cook button. Cooking is completed when Off/Warm button light is green. Serve hot in a serving bowl.



Specifications

Model		RZ-GHE18
Cooking capacity		0.18 ~ 1.8 L
Power supply		220 V
Frequency		50 Hz
Power consumption	While cooking	1300 W
	While warming	42 Wh*
Cord length		1 m
Dimensions (Approximately)	Width	29.0 cm
	Depth	39.0 cm
	Height	21.0 cm
Weight (Approximately)		5.3 kg
Safety system (Thermal fuse)		137 °C

* The average power consumption per hour of keep warm at a room temperature of 25°C.

Distributed by Hitachi Sale (Thailand) Co., Ltd.

No. 333,333/1-8 Moo 13 Bang Na Trad Road, Km. 7, Bangkio sub-district, Bangphi district, Samutprakarn 10540

Tel. 0-2335-5455 Fax 0-2316-1126, 0-2316-1127

Web Site : <http://www.hitachi.co.th> E-mail : hitachi@hitachi.co.th

Retail price included VAT : MODEL RZ-GHE18 12,990 Baht